

BXA Series

● 105°C 1,000Hrs assured

- Vertical SMD type.
- Low impedance .
- EBXA Series : Ecological capacitors with the same characteristics as BXA

Solvent-
proof



MVY

→
Low Imp.

BXA

SPECIFICATIONS

Item	Characteristics					
Rated Voltage Range	6.3 ~ 35V _{DC}					
Operating Temperature Range	-55 ~ +105°C					
Capacitance Tolerance	±20% (M) (at 20°C, 120Hz)					
Leakage Current	I = 0.01CV(μA) or 3μA, whichever is greater. Where, I : Max. Leakage current(μA), C : Nominal capacitance(μF), V: Rated voltage(V _{DC}) (at 20°C, 2 minutes)					
Dissipation Factor Tanδ(Max.)	Rated Voltage(V _{DC})	6.3	10	16	25	35
	Tanδ(Max)	0.24	0.20	0.16	0.14	0.12
(at 20°C, 120Hz)						
Temperature Characteristics (Max. Impedance ratio)	Rated Voltage(V _{DC})	6.3	10	16	25	35
	Z(-25°C) / Z(20°C)	3	2	2	2	2
	Z(-55°C) / Z(20°C)	5	4	4	3	3
(at 120Hz)						
Load Life	The following specifications shall be satisfied when the capacitors are restored to 20°C after the rated voltage applied for 1,000 hours at 105°C. Capacitance change ≤ ±25% of the initial value Tanδ ≤ 200% of the initial specified value Leakage current ≤ The initial specified value					
Shelf Life	The following specifications shall be satisfied when the capacitors are restored to 20°C after exposing them for 1,000 hours at 105°C without voltage applied. The rated voltage shall be applied to the capacitors for a minimum of 30 minutes, at least 24 hours and not more than 48 hours before the measurements. Capacitance change ≤ ±25 of the initial value Tanδ ≤ ±200% of the initial specified value Leakage current ≤ The initial specified value					
Others	Satisfied characteristics W of KS C 6421					

PART NUMBERING SYSTEM

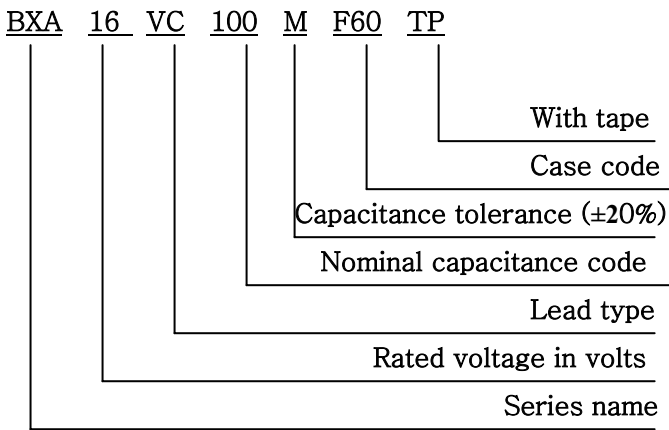

Capacitance	Code
0.1 μF	R1
0.47 μF	R47
1.0 μF	1
4.7 μF	4R7
10 μF	10
100 μF	100

Case Code	\varnothing D x L max (mm)
D56	$\varnothing 4 \times 5.6\text{L}$
E56	$\varnothing 5 \times 5.6\text{L}$
F60	$\varnothing 6.3 \times 6.0\text{L}$

DIMENSIONS OF BXA Series (Type :VC)

DIMENSIONS

Recommended solder land on PC board

Marking

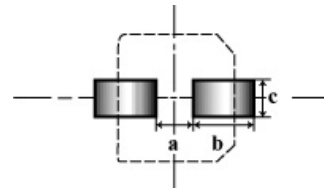
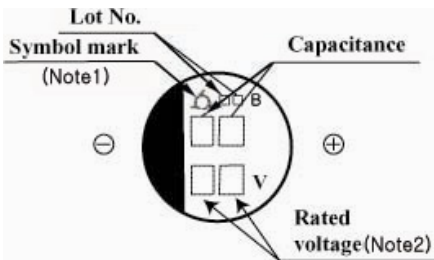
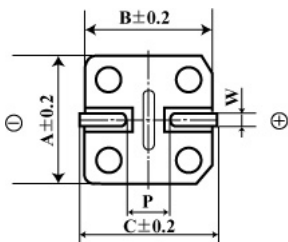
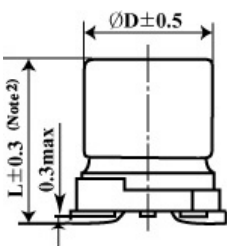
**Sold land on PC board**

Note 1 : 4 x 5.3 (D56), 5 x 5.3 (E56) is excluded symbol mark.

Note 2 : 6.3WV is marked by 6V.

Note 3 : Case Color ; Clarity Green

Case code	\varnothing D	L	A	B	C	W	P	a	b	c
D56	$\varnothing 4$	5.3	4.3	4.3	5.1	0.5-0.8	1.0	1.0	2.6	1.6
E56	$\varnothing 5$	5.3	5.3	5.3	5.9	0.5-0.8	1.4	1.4	3.0	1.6
F60	$\varnothing 6.3$	5.7	6.6	6.6	7.2	0.5-0.8	1.9	1.9	3.5	1.6

RATINGS OF BXA Series

V_{DC} μF	6.3(OJ)			10(1A)			16(1C)			25(1E)			35(1V)		
4.7													D56	1.8	80
10										D56	1.8	80	E56	0.76	150
22				D56	1.8	80	E56	0.76	150	E56	0.76	150	E56	0.76	150
33	D56	1.8	80	E56	0.76	150	F60	0.44	230	F60	0.44	230	F60	0.44	230
47	E56	0.76	150	F60	0.44	230	F60	0.44	230	F60	0.44	230	F60	0.44	230
68	F60	0.44	230	F60	0.44	230	F60	0.44	230	F60	0.44	230			
100	F60	0.44	230	F60	0.44	230	F60	0.44	230						
220	F60	0.44	230												

▲ Permissible Ripple Current(mArms/105℃, 100kHz)

▲ Impedance(Ω Max./ 20℃, 100kHz)

▲Case Code